

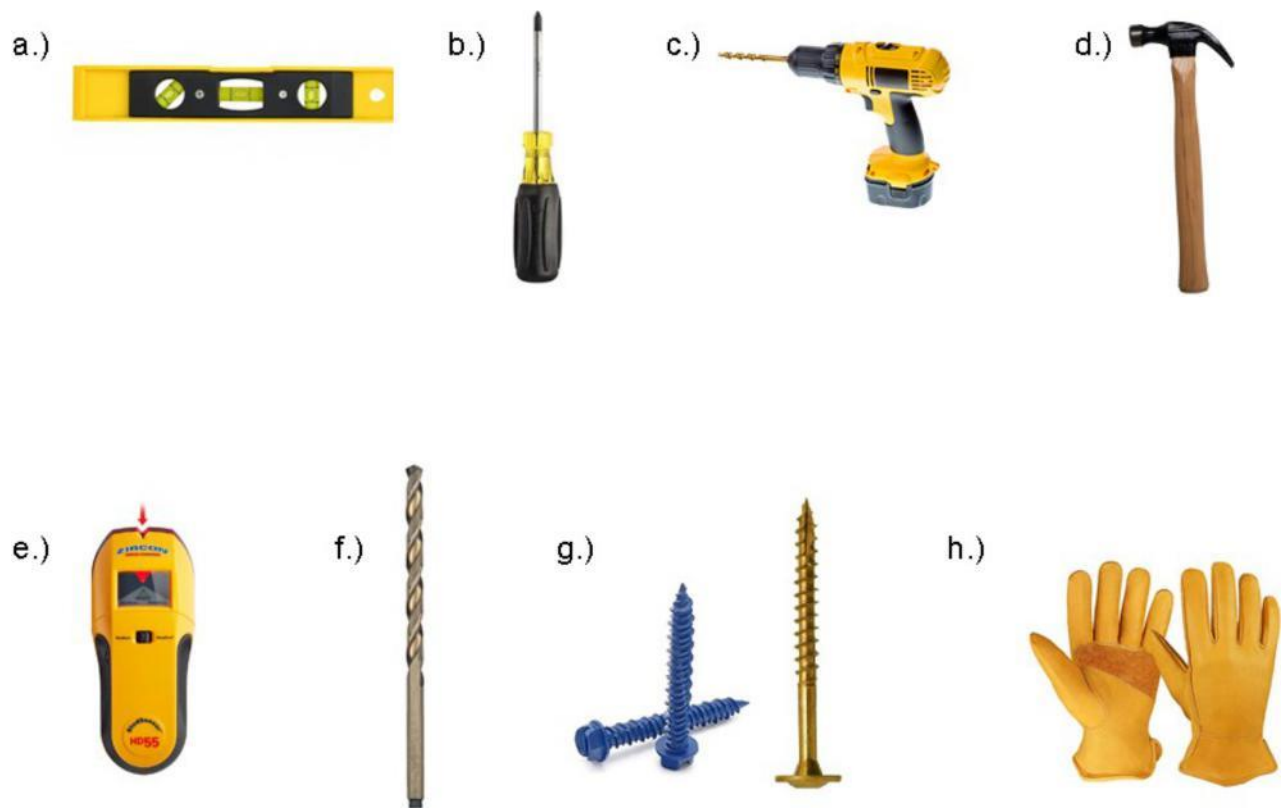

Cabinet Installation Instructions

Tools You Will Need Before Getting Started



- a. Level
- b. Screwdriver—For adjusting hinges and drawer fronts
- c. Screw gun (drill) with #2 Philips tip
- d. Hammer— For tapping the cams in
- e. Stud Finder (if attaching cabinets to a wood stud wall)

- f. Drill Bits— (see page 6 for more explanation)
 - 3/16" Drill bit used to pre-drill the sides of the cabinets when attaching cabinets together
 - 3/16" Drill bit used to pre-drill the back of the cabinets to attach the cabinet to the a wood stud wall

- a. Screws for mounting cabinets to the wall. (Note - The screws are not included because length and type of screws depend on the type of wall construction. See page 6 for more information)
- b. Working gloves—Melamine has very sharp edges and can cause cuts on the hands.

Cabinet Hardware

Cam and Dowel Hardware is used in assembling every cabinet. This creates a strong joint that makes assembly easy.

Cams are used in tops, bottoms, and backs of cabinets which attach to the dowels that are used in the sides of the cabinets.



KD-SYS6-F (Cam)



KD-SYS6-MS (Dowel)



KD-SYS6-BLK-SIDE-13



HS-CLPPLT3

Hinge Mounting Plate

It attaches to the hinge side of cabinets to receive the hinge.



HS-SC120R-HO

Standard Door Hinge

Clips onto the hinge mounting plate .



HS-SC-CRNR-45-200

Corner Cabinet Hinge

Used for diagonal corner cabinet doors. Uses the standard hinge mounting plate.



MS-6X14ESCR

Euro Screw

These are used primarily for attaching drawer slides and cabinet legs.



MS-8mmPHSCR

#8 x 1/2 Pan Head

Used for plastic parts bin rails.



MS-8MMX1.25WSCR

Washer Head Screw

These screws are used for drawer fronts, countertop mounting and screwing cabinets together.



MS-8-32-1.625MS

#8-32 x 1-5/8 Truss Head

Used on 4" tall drawer boxes where the drawer box covers the holes for the pull. (See page 11)



MS-BMPPR-03

Door/Drawer Bumpers

Bumpers are attached to doors and drawers to cushion the close.



HS-SHLFPIN

Shelf Pins

These pins are used to support adjustable shelves.

Continued...



HS-SC165R-200
Pie Cut (90*) corner cabinet hinge.
Used to connect door to cabinet. Uses standard hinge mounting plate



MS-8x1.25FH
#8 x 1.25" Flat Head
Used to attach corner cabinet, backsides and angle back.



HS-CORNER-200
Pie Cut (90*) corner cabinet hinge.
Pie Cut Used to connect door to door. Uses standard hinge mounting plate.

Start Here — Unpacking & Assembly Instructions

Making sure your cabinets arrive safely is extremely important, that is why we build crates around every job. The diagram below shows how we typically stack the parts in a crate. Larger orders may require (2) or more crates. If there are multiple crates the layers remain the same but may be separated into different crates.

CAUTION: Corners of the melamine are sharp

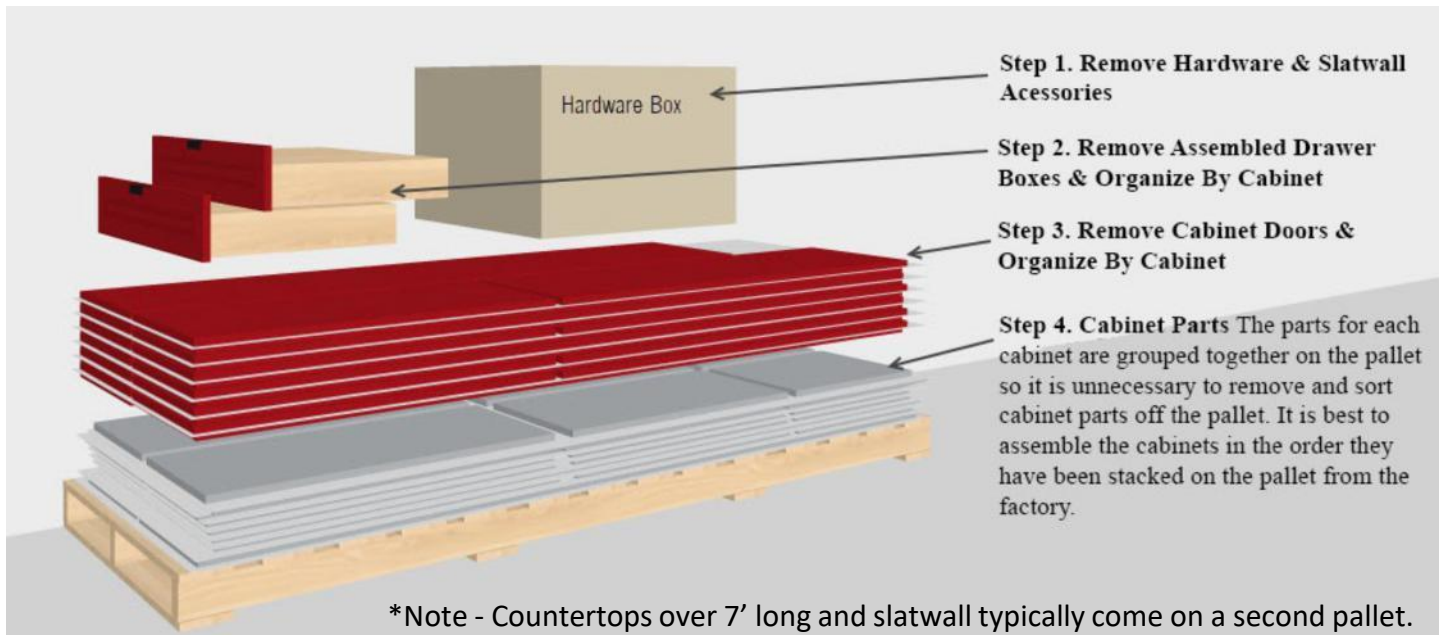

Please Watch Assembly and Installation Videos

www.GarageCabinets.com/installation

Several videos are uploaded to our website to help with assembly and installation. Scan the QR code below with your camera phone to take you to the videos.

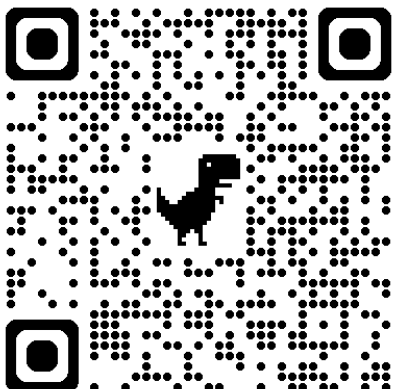

Explanation of the Product Part List and the Part Labels

1. Every Cabinet (or Product) has a **Product Part List** W/exploded view drawing (like the one shown below). This document is specific to you and your order.



Product Part List

Greenberg Casework Co., Inc.

Work Order: 30620 - GordonWS

Project Name: Batch 10-28-20

Room Name: 30620 - GordonWS

Product ID - 20.02 QTY - 1 WS-T1D W 16.5in x H 75.12in x D 23.78in

Page 2 of 12

10/20/2020

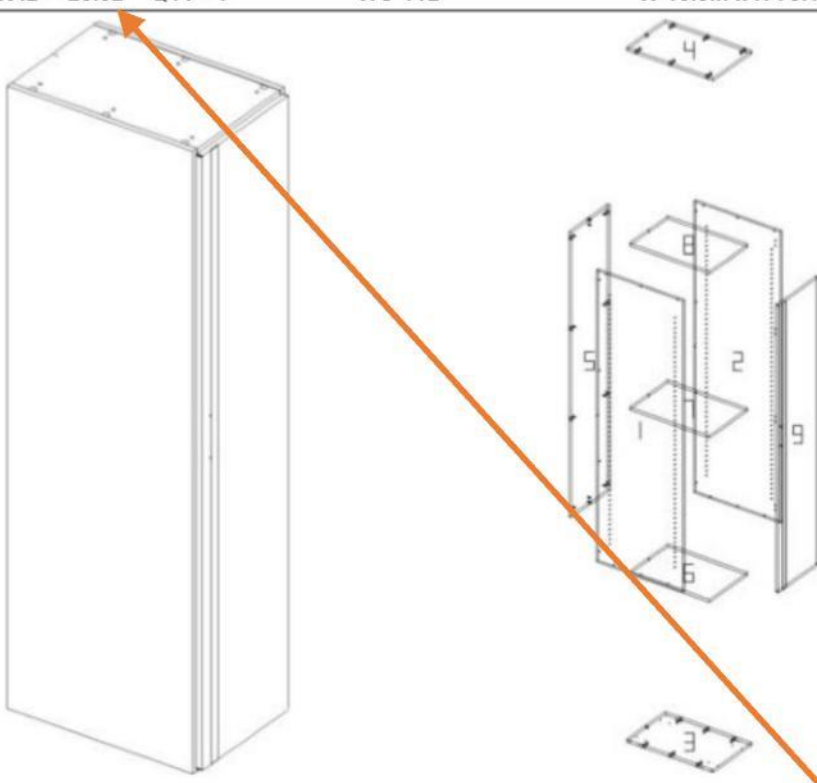

Index	Part Name	Width	Length	Index	Part Name	Width	Length
1	Tall Left Side	23.78	x 75.12	2	Tall Right Side	23.78	x 75.12
3	Tall Bottom	23.78	x 15	4	Tall Top	23.78	x 15
5	Tall Thick Back	15	x 73.58	6	Tall Adj Shelf	21.92	x 14.84
7	Tall Adj Shelf	21.92	x 14.84	8	Tall Adj Shelf	21.92	x 14.84
9	Door Tall Right	15.63	x 74.12				

1. Every cabinet part on the pallet has a label
 - A. The part label references the **Product ID** the part goes to (See Orange Arrow)
 - A. The part label gives the part description that is referenced in the **Product Parts List** (See Blue Arrow)



Important Assembly & Installation Notes

1. Positioning of the cams

Proper cabinet assembly must be followed to prevent possible failure.

All cabinet Top and Bottom panel **CAMS MUST BE FACING DOWN**, towards the floor.

All cabinet back panel **CAMS MUST BE FACING TOWARDS THE WALL**.

****Failure to assemble the cabinets per manufacture instructions will result in a non-warranty claim.****

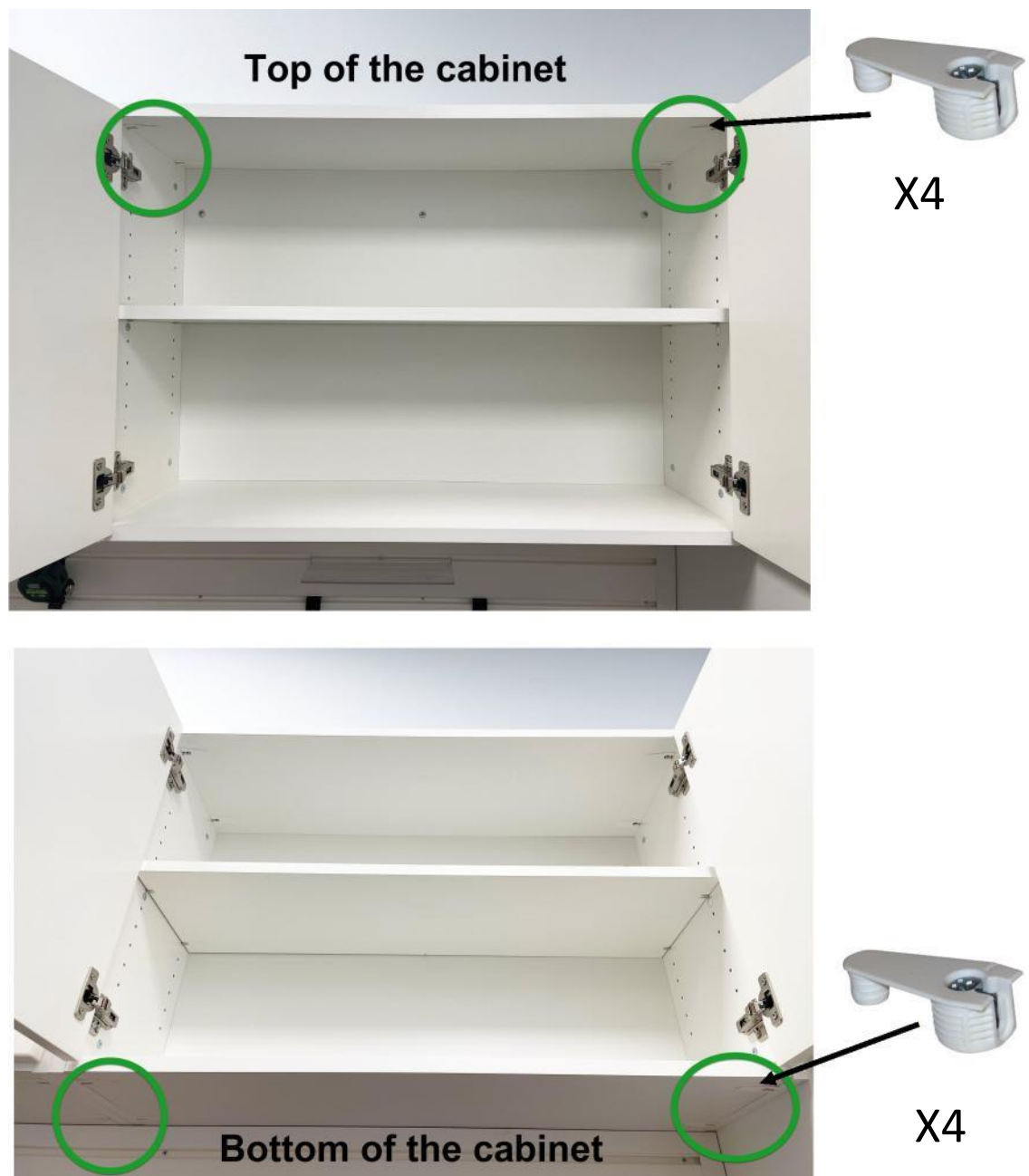

2. Moving the Cabinets

When assembling cabinets, it is important to not move the cabinet until the back is installed. This is especially important with tall cabinets. The back is what gives the cabinet the structure to keep from rack-ing.

3. Screwing Cabinets To the Wall

As mentioned previously, cabinets should always be attached to the wall. The screws are not included because length and type of screws depend on the type of wall construction.

If the wall construction is wood studs and drywall we recommend Washer head or Wafer Head cabinet screws available at any of the home centers. The screw must go at least 1-1/4" into the wood stud (More is better and this dimension does not include any sheathing or drywall that may be over the studs, you must add extra length for sheathing). Keep in mind that there may be more than one layer of drywall on the wall, this is especially true for the wall between the garage and the house if the garage is attached. Code in many areas requires two layers of drywall to create a fire wall between the garage and the house. There are

several suppliers of these screws such as GRK, Spax, Hillman, Fast-cap.



Typical walls have studs 16" on center, so we suggest that in each cabinet you have 2 screws in every stud, one at the top and one at the bottom. (For example: if your cabinet is 32" wide, you will have 2 studs to screw into for a total of 4 screws for that cabinet).

If the wall construction is cement, then use a hex head 1/4" TapCon brand masonry screw, making sure the screw goes into the concrete a minimum of 1-1/4". **(Note: Use a 5/16" nut driver rather than a Philips bit.)** You will need at least 4 screws per base or upper cabinet. Use 8 screws for a tall cabinet and space them evenly into vertical rows of 4. Attaching to concrete can be tricky. Be sure not to strip the screws when inserting them. A little lubricant on the screw, like WD-40, will help the screw go into the concrete.

4. Leg Installation

There are predrilled holes in the bottom of the Base and Tall Cabinets where the legs and screws are to be installed. The screws used for the legs are a 6mm x 14mm Euro Screw (**MS-6x14escr**) as shown below, and on page 3 of this installation packet.

Euro Screw (**MS-6x14escr**) Cabinet Leg



5. Screwing Cabinets To Each Other

We highly recommend the cabinets to be screwed together to avoid any movement or gaps between cabinets. We provide **MS-8MMX1.25WSCR Drawer Front Screw** to attach the cabinets. The screws should be placed in the front of the cabinets. One screw on the front top corner of the cabinet and one screw on the front bottom corner of the cabinet (as shown in the picture below).

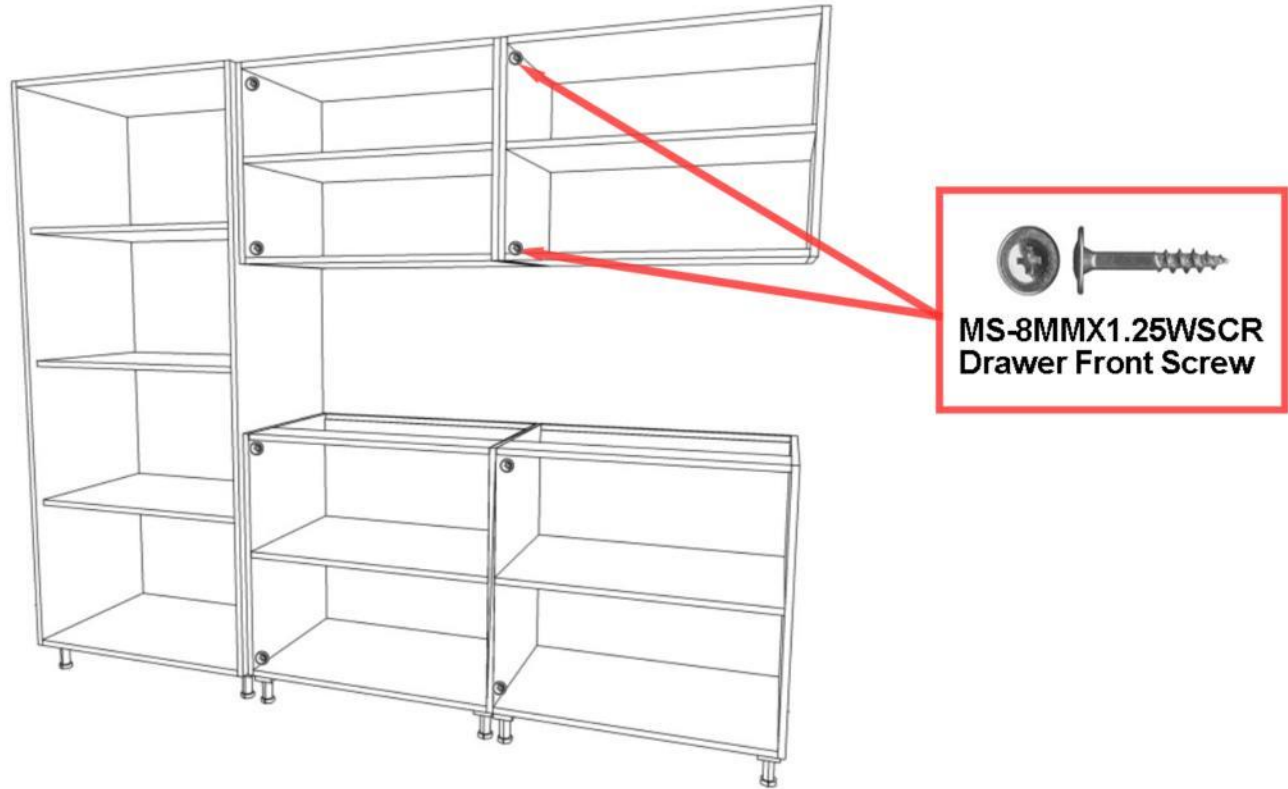

1. Door Hinges - Adjustment

When installing hinges into the door turn the hinge cup screws 1/2 turn to secure the hinge to the door.

Once the door is hung on the cabinet the hinges will most likely need to be adjusted to get the door to fit properly. The hinges are 6 - way adjustable.

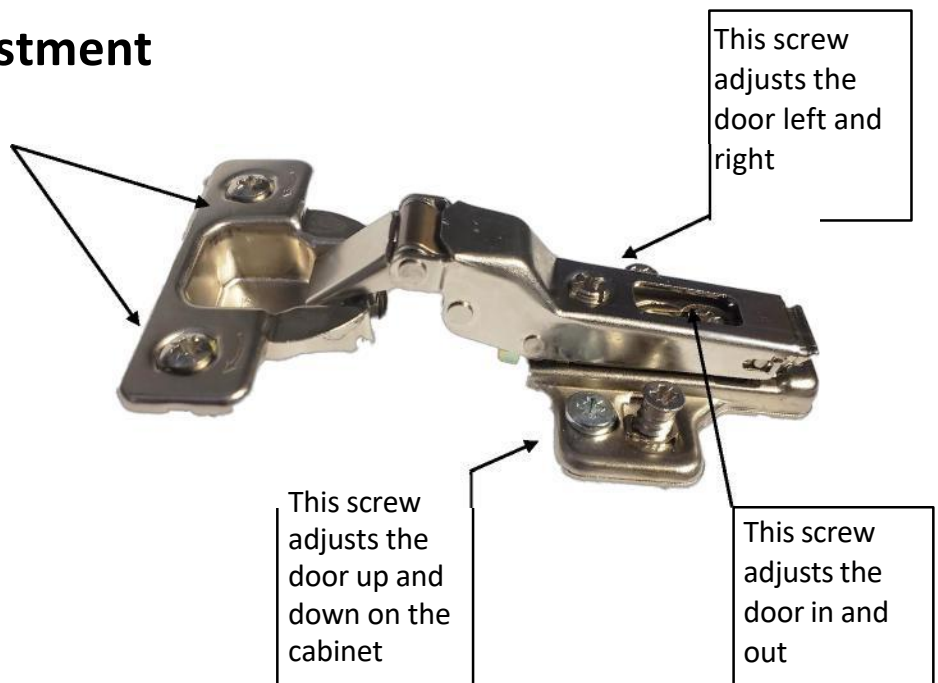

7. Adjusting Drawer Fronts

Drawer fronts come attached to the drawer boxes for ease of assembly. Once the cabinets are installed there is a small amount of adjustment built in to get them perfectly aligned.

There are two screws holding the drawer front on, to adjust the drawer front loosen the screws slightly and adjust the front and tighten again.

Once the drawer fronts are aligned there are additional drawer screws in the hardware box that need to be installed in order to keep the drawer front properly aligned.



MS-8MMX1.25WSCR
Drawer Front Screw

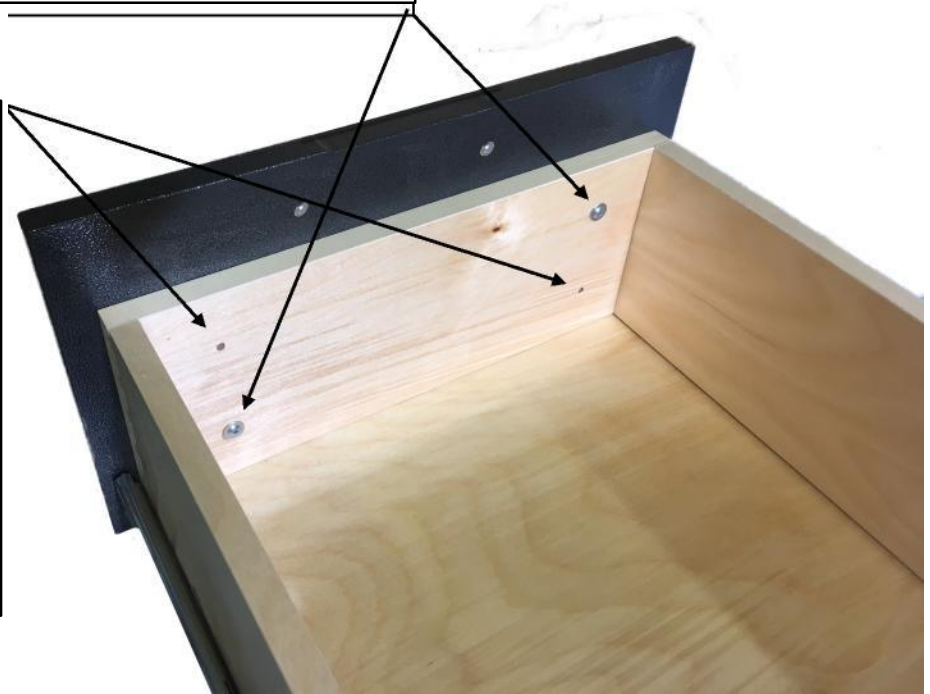

Drawer Pulls on 4" Drawers

Once the drawers are aligned properly, the drawers box needs to be drilled out using a 3/16" bit, use the predrilled holes on the drawer front to drill through the drawer box. Then use the long drawer pull screws (shown below) to attach the drawer pull.



MS-M4X45SCR-BA
Drawer Pull Long Screw



Lifetime Warranty on Workspace Cabinets

WorkSpace Garage Cabinets are warranted for a lifetime from the date of purchase when installed and maintained following instructions. We will repair or replace defective products or defects in material or workmanship.



To qualify, cabinets must be properly installed and in the possession of the original owner. Covered items include cabinet doors and cabinet boxes. Minor scratches, dents, nicks and scuffs are normal wear and are not covered. Deliberate or excessive abuse is not covered.

Overloading shelves, which causes bowing of the shelves, is also not covered. Maximum recommended weight capacity is 50 lbs per shelf, including the cabinet top and bottom shelf.

To ensure the long-term durability and safety of your cabinets, our Lifetime Guarantee requires that the legs remain in place. The steel legs provide crucial support and stability for the cabinets, safeguarding their performance and your safety. For added clearance, we offer 6"–8" legs that allow for easier cleaning while maintaining the structural integrity of your cabinets for decades of reliable use.

Cabinet Maintenance

Cleaning the cabinets is an important step to have your cabinets looking the best. That is why we highly recommend using warm water with a little bit of dish soap to clean your cabinets. Please do not use Windex or any harsh cleaning chemicals.

Lifetime Warranty on Hardware

All WorkSpace hardware is covered by Lifetime Warranty.

To qualify, cabinets must be the original, unmodified installation and in the possession of the original owner.

Lifetime Warranty include hinges, drawer slides, pulls, legs, cams. Excessive weight and deliberate or excessive abuse is not covered.



Caution: Do Not Store Chlorine Inside the Cabinets

Storing Chlorine inside your cabinets will cause the hinges and any metal fasteners to rust.

Chlorine can be corrosive to certain metals. When chlorine gas dissolves in water, it forms hydrochloric acid, which can corrode metals such as iron, steel, and copper. This corrosion can be accelerated with the presence of moisture and oxygen in the air. It's important to consider the potential corrosive effects of chlorine when storing it.